

# G125BE Low-NOx Residential Oil Boiler

# Buderus



## Great for Your Home. Better for the Environment.

The modern and functional design of the G125BE is attractive and stylish. Yet with its higher efficiencies, low pollution levels and weather responsive energy management system, the G125BE oil boiler has economical and ecological style as well.

**89+%**  
AFUE's



Approved for  
**B5 Fuel Oil**

**Comfortable. Efficient. Intelligent Heating.**

# G125BE

## Better for Your Home

The Buderus G125BE System is innovative European Heating technology at its best. Based on the high quality and superior reliability of the Buderus G115, the world's best selling oil boiler, the G125BE boiler brings new advances in oil burning technology — a modern, low emissions, high efficiency oil burner.

The G125BE System includes:

- Buderus GL-180M Cast Iron Boiler
- BE Low-NOx Burner
- Logamatic Control
- Tigerloop® Ultra™ oil de-aerator and high efficiency oil filter



At the heart of the G125BE System is the cast iron boiler. Buderus uses its patented GL-180M flexible cast iron to ensure that the boiler resists thermal shock. Designed without a heat-consuming refractory or target wall, service and maintenance calls are minimized, while fuel efficiency and heat transfer are maximized. Sections are securely joined together and sealed by profiled, beveled steel push nipples ensuring a long life with no leakage. Special compounds provide a gas-tight seal for safe and efficient operation. With a full 3½" of thermal insulation around the boiler, including underneath, standby and stack temperature losses are virtually eliminated, thus improving the overall efficiency. Additionally the G125BE has 8 flue baffles for enhanced heat transfer contributing to the very high AFUE efficiency of the G125BE.

Since 1995 over a quarter of a million G125BE Systems have been installed. Now this proven European technology, which is both highly efficient and environmentally conscious, is available in North America.

## Innovative, Environmentally Friendly Technology

The strength of the G125BE is its state-of-the-art Low-NOx Buderus BE burner designed to burn at lower temperatures than conventional burners. Internal recirculation of combustion gases assists in vaporizing the liquid oil droplets and lowers the flame temperature which results in complete combustion and inhibits the formation of nitrogen oxide — NOx. The complete carbon combustion, produces virtually no soot residue, higher fuel utilization and a cleaner boiler throughout the heating season. While this sounds very high tech, every G125BE System is factory tested to ensure years of dependable operation.

## Intelligent Heating — Added Comfort

The G125BE comes with a Logamatic 2107 control which features microprocessor-based controls to intelligently manage both your heat and domestic hot water. The Logamatic 2107 has 16 standard functions, including:



- Domestic hot water priority
- Condensate protection
- DHW recirculation pump operation
- Automatic Summer/Winter change over
- Outdoor reset
- Vacation mode
- LCD display
- Compatible for integration of solar panels

Options for the Logamatic 2107 are also available for room sensor and the ability to control a mixing station for mixed temperature applications.

## Need Hot Water?



A Buderus domestic hot water tank is so well insulated that it loses less than ¼ °F per hour. Available in a vertical, or a horizontal space saving model that installs under the boiler, these tanks have a higher recovery rate than stand alone or tankless coil models. By

pairing a Buderus LT tank or vertical ST tank with the G125BE you will have the utmost in European technology and style. Not only space saving and attractive, this Buderus system will give you years of increased boiler efficiency, system longevity and minimized service calls when you insist on a Buderus tank with your G125BE System.

## The Ultimate in Fuel Conditioning

The Tigerloop® Ultra™ oil de-aerator and high efficiency oil filter comes standard on every G125BE. The Tigerloop® Ultra™ features a 10 micron spin-on oil filter to deliver only conditioned fuel to the burner, resulting in a cleaner burn and lower emissions. And while you'll



like the additional fuel economy the Tigerloop® Ultra™ provides the G125BE, your heating contractor will appreciate its ease of installation and maintenance, simple routing of oil lines, easy mounting on the side of the boiler, as well as a vacuum gauge to indicate

the condition of the filter and a viewing window which shows the condition of the oil.

## Unparalleled Energy Efficiency

Keeping your home comfortable and warm is a high priority - and this can be achieved with a lower annual operating cost. Designed in Europe, where fuel costs are significantly higher and environmental regulations are more stringent, the G125BE is built to maximize the heating value of every ounce of fuel and to burn cleaner with less impact on the environment.

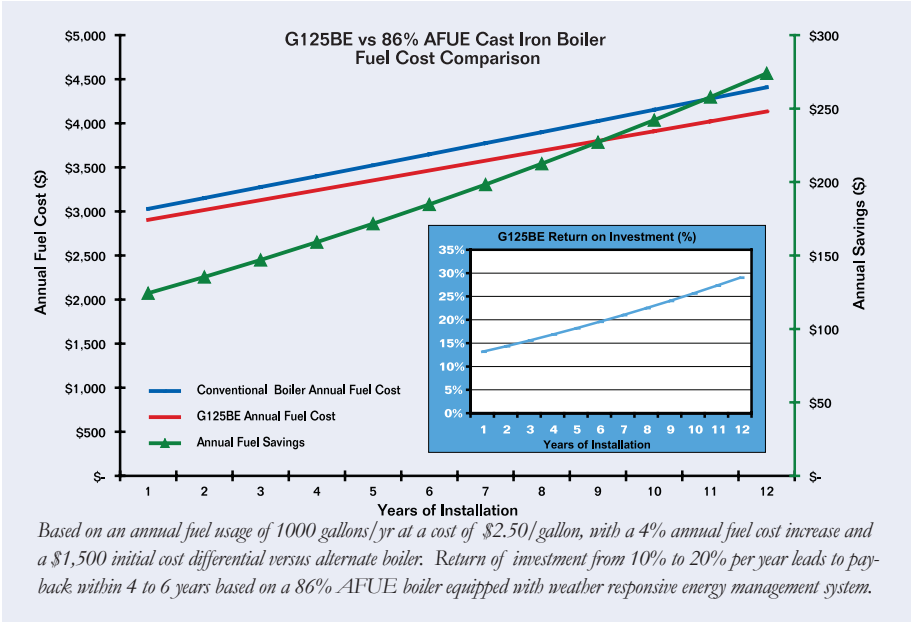

As seen in the graph, the G125BE starts to pay for itself the very first year. The annual fuel savings per year of the G125BE versus that of new conventional boiler are clear — you can imagine what it will save in fuel costs vs your existing boiler. And because the G125BE System will run as clean and efficiently 10, 15, 20 years from now as it did the first year — the annual fuel savings over a conventional system will increase steadily.

Energy Star ratings for boilers are based on an Annual Fuel Utilization Efficiency (AFUE) rating, which is a ratio of the heat produced to the energy consumed on an annual basis. With AFUE's above 89% the G125BE boasts the highest efficiency ratings available in any non-condensing oil boiler.

The Buderus G125BE System is also designed for ease of installation and maintenance. Standard features include integrated handles for ease of transporting, adjustable rubber screw-in feet for leveling, rear tappings and flue connection, baffles and clips for adjusting stack temperatures, a reversible full "swing" burner door, as well as front access plugs, ensure that the G125BE System is not only efficient, but it is easy to install and maintain.

## Ideal for All Applications

The G125BE System is ideal for new installations or as a replacement for virtually any make or model of boiler. Constructed with superior materials and designed by the industry's leading engineers, the G125BE System has set the standard for the industry. With two CSA approved venting options either into a chimney or directly through the wall, the G125BE allows a wide range of installation possibilities.

Acknowledged as the leader in hydronic heating, a Buderus boiler offers innovative design, quality manufacturing, exceptional efficiency and performance. Packaged together from one manufacturer — Cast iron boiler, Low NOx burner, Logamatic control, and Tigerloop® Ultra™ — the G125BE System is designed and built to the highest industry standards and offers you the best in class oil boiler for your home and for the environment.

## Technological Advantages

- Premixed fuel/air combustion for lower NOx levels as well as full and complete combustion and stable oil burning.
- Trouble free operation with oil pre-heater, Tigerloop® Ultra™, plug and play connections and proven technology.

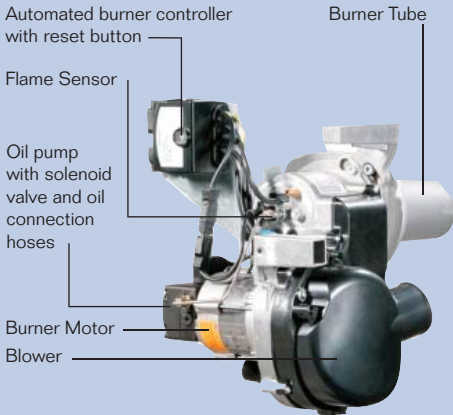

- Premixed combustion with higher CO<sub>2</sub>, less excess air, higher AFUE efficiencies and lower fuel consumption.
- High efficiency 10 Micron Filtration.
- Flue Gas recirculation for complete gasification of oil droplets, clean combustion and higher efficiencies.
- Flame sensor photo cell

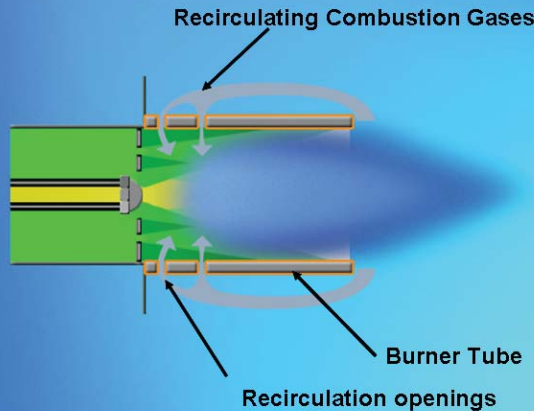

# G125BE

## Low-NOx Residential Oil Boiler

Abbreviations	
VK	Boiler Supply
VS	Connection (plugged)
RK	Boiler Return
RS	Connection (plugged)
EL	Boiler Drain (Connection for drain valve)
VSL	Connection (plugged)

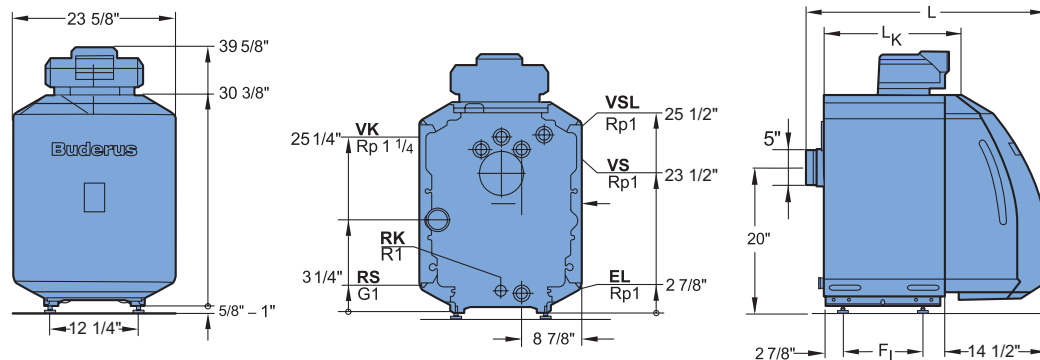

### Clearance Requirements

Front	Side	Rear	Top	Galvanized Vent Pipe	Flex Insulated Oil Vent	AT-4 Exhaust Only Termination	FT-4 Concentric Termination
24"	15"	20"	6"	18"	1"	1"	1"

Model	G125BE/21	G125BE/28	G125BE/34
<b>Performance Data</b>			
Gross Output MBH	72	96	116
# of Sections	3	4	5
Net IBR (MBH)	63	83	101
Firing Rate (GBH)	.60	.80	1.0
AFUE %	89.8	89.4	89.1
<b>Piping Connections</b>			
Vent Connection Size	5"	5"	5"
Supply	1 1/4"	1 1/4"	1 1/4"
Return	1"	1"	1"
<b>Dimensions</b>			
Total Boiler Length (L)	34 5/8"	39 3/8"	44"
Boiler Block Length (LK)	21 1/8"	25 3/4"	30 1/2"
Boiler Feet Spacing (FL)	11 3/8"	16 1/8"	20 7/8"
Dry Weight (lbs.)	386	459	513

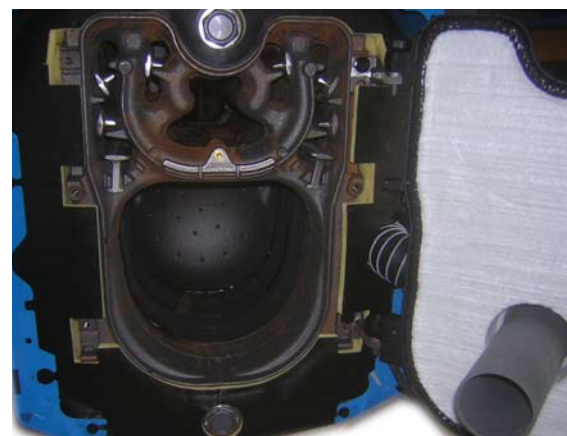

### Efficiency Enhancing Features

- 8 flue baffles for improved heat retention
- Low NOx ceramic burner tube with recirculation opening
- Full swing burner door for superior access
- Suitable for chimney venting and sealed combustion with an integrated 4" air intake connection that comes standard in the back of the boiler for ease of installation

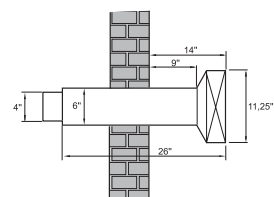

AT-4 Aerocowl Termination

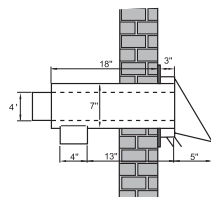

FT-4 Concentric Pipe-in-Pipe Termination

#### Venting Information

CSA approved with two 4" 90° elbows, and up to 6' of 4" regular smoke pipe for short vent runs. For longer runs use up to 10' of flexible stainless steel insulated oil vent.

Use 4" metal pipe for air intake. Use at least 6' to 8' of 4" metal pipe for air intake in conditioned space in cold climates (below -20°F)

Direct vent burners are equipped with pre-and post-purge cycles for safe, complete exhaust of all combustion products, while cooling oil burner nozzle for positive shut-off.

One of the two CSA certified terminations are required for use with G125BE series boilers for direct vent applications. Both terminations are "zero clearance" systems for easy and versatile applications.



# Buderus

BBT North America Corporation  
50 Wentworth Avenue  
Londonderry, NH 03053  
Tel: (603) 552-1100  
Fax: (603) 584-1681

Subject to change without notice

© 2008 Buderus

Part Number 44499031 09/07